

INSTRUCTION MANUAL

Electric chain hoist GCH 250/500 • GCH 1000 • GCH 1600/2000/2500

GIS CHAIN HOIST

 SWISS QUALITY

GCH

GCHK

GCHS

GCHH

GCHR

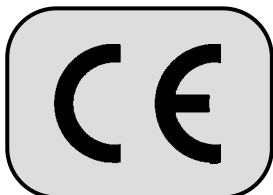

M A D E I N S W I T Z E R L A N D



Table of contents

0	General information.....	4
0.1	General safety information	4
0.1.1	Safety and hazard precautions.....	4
0.2	General safety specifications and procedures.....	4
0.2.1	Warning paint / Marking / Danger signs	4
0.3	Special safety directions.....	4
0.4	Notes on hazard protection	5
0.4.1	Hazards caused by mechanical influences	5
0.4.2	Hazards caused by electrical energy / power supply	5
0.4.3	Sound level (SPL).....	6
0.5	Technical status	6
0.5.1	Technical data	6
0.5.2	Recurrent checks.....	6
0.5.3	Warranty	7
0.6	Operational parameters.....	7
0.6.1	Directions for using the instruction manual	7
1	Description	8
1.1	Operating conditions.....	8
1.2	General description	9
1.3	Special models	10
2	Start-up	11
2.1	Transport and assembly	11
2.2	Connection	11
2.2.1	Electrical connection	11
2.2.2	Load chain.....	12
2.2.3	Limit switch.....	14
2.2.4	Chain bucket.....	15
3	Service and maintenance.....	15
3.1	General regulations for service and maintenance work	15
3.2	Service and maintenance	16
3.2.1	Maintenance overview.....	16
3.2.2	Service overview	16
3.2.3	Brake system.....	16
3.2.4	Load chain	17
3.2.5	Limit stop assembly.....	17
3.2.6	Gearbox.....	17
3.2.7	Slip clutch	17
3.2.8	Suspension parts.....	18
3.3	Ordering spare parts.....	18
4	Measures for obtaining a safe period of operation.....	18
4.1	Determining the actual utilization period S	18
4.2	General overhaul	18
5	Appendix	19
5.1	Technical data	19
5.2	EC Declaration of conformity.....	21
5.3	EC Declaration of incorporation.....	22

Spare parts / Ordering spare parts

The correct order numbers for original spare parts can be obtained from the relevant spare parts list. Please ensure that you have the following data on your chain hoist to hand. This will enable the correct spare parts to be supplied without delay.

Electric chain hoist type :

Manufacture number :

Year of manufacture :

Load capacity :

Original spare parts for the electric chain hoist can be acquired from the following addresses:

1. Manufacturer

GIS AG
Hebe- und Fördertechnik
Luzernerstrasse 50
CH-6247 Schötz

Tel. +41 (0)41 984 11 33

Fax +41 (0)41 984 11 44

tel@gis-ag.ch

www.gis-ag.ch

2. Agent

.....

.....

.....

.....

.....

.....

0 General information

0.1 General safety information

0.1.1 Safety and hazard precautions

The following symbols and terms are used in this instruction manual for safety and hazard instructions:



DANGER !

Non-compliance, either in part or full, with operating instructions marked with this symbol can result in serious personal injury or even death. Danger notices must be **strictly** complied with.



CAUTION !

Non-compliance, either in part or full, with operating instructions marked with this symbol can result in major damage to machinery, property or material. Cautionary notices must be **strictly** adhered to.



NOTE

Following the instructions marked by this symbol will lead to more effective and straightforward operation. "Note" directions make work easier.

0.2 General safety specifications and procedures

The instruction manual for the electric chain hoist must always be available within the operating area of the hoist. The instructions mentioned in this manual must be strictly adhered to. Furthermore, supplementary to the instruction manual, the statutory regulations governing general accident prevention and environmental protection are to be enforced.

Operating and service personnel must have read and understood the operating instructions, in particular the safety instructions, before commencing work. Protective equipment must be made available for operating and service personnel and worn at all times.

The operator or his representative is responsible for supervising operating personnel and ensuring they are aware of the hazards and safety implications of working with the electric hoist.

0.2.1 Warning paint / Marking / Danger signs

- Lubricate chain..... figure 0-1
- CE symbol..... figure 0-2
- Model plate figure 0-3
- Data plate..... figure 0-4
- Voltage..... figure 0-5

Figure 0-1

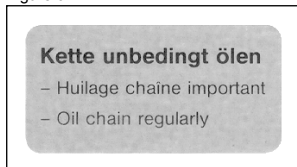

Figure 0-2



Figure 0-3

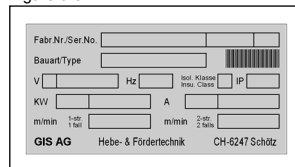

Figure 0-4

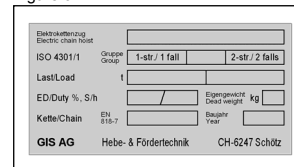
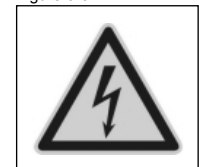

Figure 0-5



0.3 Special safety directions

Transport and assembly:

- Electric chain hoists, single parts and large components should be carefully affixed to suitable and technically acceptable hoisting apparatus / load lifting members

Connection:

- Connection work is only to be performed by personnel specifically designated and trained for the job

Start-up / operation:

- Before initial start-up, as well as daily start-up, carry out a visual check and carry out the predefined user-checks routine
 - Only operate the electric chain hoist if the protective and safety equipment provided is ready and working
 - Damage to the electric chain hoist and changes in its operational characteristics must be reported immediately to the person responsible
 - After use, or when in a non-operational mode, the chain hoist should be secured against unauthorised and unintentional use
 - Refrain from hazardous procedures
- See also operational parameters (chapter 0.6)

Cleaning / service / repair / maintenance / refitting:

- Use the working platforms and ladders provided for assembly work above body height
- Do not use machine parts for this purpose
- Check electrical cables for damage or wear
- Ensure any oils or other agents used are discharged, collected and disposed of safely and in an environmentally sound manner
- Reassemble and check safety apparatus that has been disassembled for servicing or repairing the hoist once service and repair work has been completed
- Adhere to predefined testing and service intervals specified in the instruction manual
- Follow the directions in the instruction manual regarding exchanging parts
- Operating personnel should be informed before commencing special or refitting work
- Secure the repair working area
- Prevent the electric chain hoist from being inadvertently switched on during service or repair work
- Erect warning signs
- Disconnect the power cable and ensure it cannot be inadvertently switched on again
- Retighten screw connections that have been loosened for repair or service work
- Replace parts that are not reusable, such as O-rings, gaskets, self locking nuts, split-pins and washers

Shut down / storage:

- Clean and preserve (lubricate/grease) the chain hoist before long periods of inactivity or storage

0.4 Notes on hazard protection

Hazardous areas must be clearly marked by warning signs and cordoned off. It must be ensured that warnings regarding hazardous areas are given due attention.

Hazards can stem from:

- incorrect application
- not following safety directions properly
- not carrying out test and service work thoroughly

0.4.1 Hazards caused by mechanical influences**Physical injury:****DANGER !****Unconsciousness and injury through:**

- crushing, shearing, cutting and twisting
- drawing in, ramming, piercing and rubbing
- slipping, stumbling and falling

Causes:

- crush, shear and twist area
- parts rupturing or bursting

Safety options:

- keep floor, equipment and machinery clean
- eliminate leakages
- observe the required safety distance

0.4.2 Hazards caused by electrical energy / power supply

Work on electrical apparatus or machinery may only be performed by qualified electricians or persons under the supervision and guidance of qualified electricians, in accordance with predefined electrotechnical regulations.

Physical injury:**DANGER !****Death from electrical shock, injury and burns through:**

- contact
- faulty insulation
- faulty servicing or repair work
- short circuit

Causes:

- contact with, touching or standing too close to uninsulated power and voltage supply terminals
- use of uninsulated tools
- exposed electricity supply terminals following insulation failure
- inadequate safety checks following repair work
- incorrect fusing

Safety options:

- isolate machinery and equipment designated for repair or service work before commencing such work
- first check isolated parts for voltage
- regularly check electrical fittings
- replace loose or damaged cables immediately
- always replace blown fuses with fuses of the correct value
- avoid contact with or touching live terminals
- only use insulated tools

0.4.3 Sound level (SPL)

Tests on the chain hoist sound level are performed at a range of 1, 2, 4, 8 and 16 metres from the centre of the chain hoist motor to the measuring device.

Measurement of SPL according to DIN 45 635.

The SPL was measured:

- during operation of electric chain hoists on factory site
- during open-air operation

Table 0-1 Sound level

Types	Measuring distance	1 m	2 m	4 m	8 m	16 m
	Measurement	dBA				
GCH 250/500	a)	75	72	69	66	63
	b)	75	69	63	57	51
GCH 1000	a)	72	69	66	63	60
	b)	72	66	60	54	48
GCH 1600/2000/2500	a)	75	72	69	66	63
	b)	75	69	63	57	51

0.5 Technical status

The present document was written in 2010. It corresponds to directive 2006/42/EC of the European Parliament and of the Council of 17 May 2006.

0.5.1 Technical data

- 0.5.1.1 Models GCH.....table 0-2, page 19
- 0.5.1.2 Models GCHK.....table 0-3, page 19
- 0.5.1.3 Models GCHS.....table 0-4, page 20
- 0.5.1.4 Models GCHHK.....table 0-5, page 20
- 0.5.1.5 Models GCHHTD.....table 0-6, page 20
- 0.5.1.6 Models GCHRtable 0-7, page 20

0.5.2 Recurrent checks

Each device/ unit operator should adequately note all checks, maintenance and inspections performed in the log book, and have these confirmed by the competent person in charge.

Incorrect or missing entries will lead to forfeiture of the manufacturer's warranty.

**CAUTION !**

Equipment and cranes should be periodically tested by an expert. Basically, visual and functional checks should be performed to determine the condition of components as regards damage, wear, corrosion or other modifications. In addition, safety equipment is assessed for completeness and efficiency. It may be necessary to dismantle the equipment under inspection to correctly assess expendable parts.

**CAUTION !**

Suspension apparatus must be inspected over its entire length, including covered or hidden parts.

**CAUTION !**

All periodical inspections should be arranged by the operator.

0.5.3 Warranty

- the warranty is void if the installation, operation, testing or maintenance is not carried out according to these instructions
- troubleshooting and repair under warranty may only be carried out by qualified persons and only after consultation and agreement with the manufacturer / supplier. Any modifications to the product or the use of non-original replacement parts will void the warranty

0.6 Operational parameters

Electric chain hoists of the series GCH are hoists of differing load capacities. They can be installed as stationary or mobile units. Electric chain hoists are manufactured in accordance with the latest technical developments and recognised safety standards, and are tested for safe operation by the manufacturer.

Electric chain hoists are approved by various international institutes such as BG and others.

Electric chain hoists of the above series may only be used when in an acceptable technical condition, in accordance with their operating parameters, by trained personnel in a safe and responsible manner.

The operational parameters of the electric chain hoist also encompass compliance with the pre-defined operating, service and maintenance requirements laid down by the manufacturer.

The operational parameters do not include:

- exceeding the defined load capacity
- pulling the load diagonally (see figure 0-5)
- heaving, pulling or dragging the load
- transporting persons
- transporting loads when personnel are underneath
- standing under suspended loads (see figure 0-6)
- transporting excessive loads
- pulling on the control cable
- failing to observe the load hook constantly
- running the chain over edges
- failing to observe the load constantly
- allowing the load to fall due to a slack chain
- use at temperatures below -15°C or above $+50^{\circ}\text{C}$
- use in an explosive environment

See also chapter 0.3.

Figure 0-5

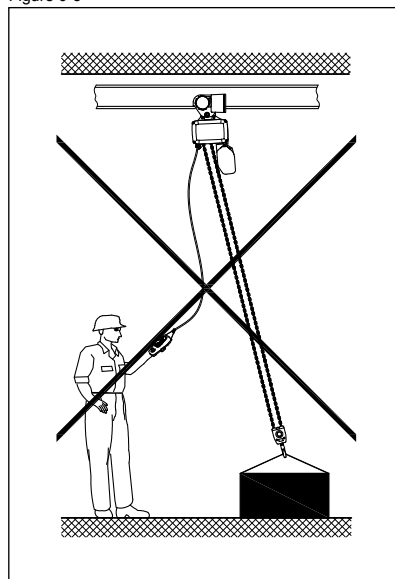
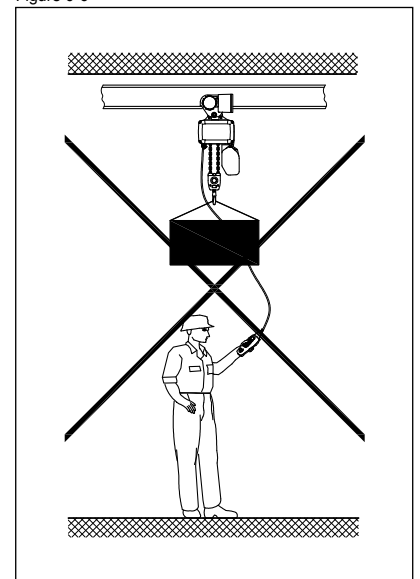

Figure 0-6



Inching operations, ground mooring and driving against the limit switches should be avoided. The manufacturer accepts no responsibility for damage to equipment and third parties ensuing from such action.

0.6.1 Directions for using the instruction manual

This instruction manual includes the following chapters:

- | | | | |
|---|-------------------------|---|---|
| 0 | General information | 4 | Measures for obtaining a safe period of operation |
| 1 | Description | 5 | Appendix |
| 2 | Start-up | | |
| 3 | Service and maintenance | | |

Supplementary to the instruction manual, the following documentation from the operator must be noted:

- Declaration of conformity
- Log book
- Spare parts list(s)
- Circuit diagrams

Page and figure numeration:

The pages are consecutively numbered. Blank pages are not numbered, however are calculated together with the consecutive pages. Figures are numbered consecutively by chapter.

Example:

Figure 3-1 means: in chapter 3, figure 1

1 Description

General:

The GCH series consist of the following models:
GCH, GCHK, GCHS, GCHHK, GCHHTD, GCHR

1.1 Operating conditions

Classification according to application requirements:

Electric chain hoists and travelling gears are classified according to the following regulations into ISO Groups:

- DIN EN 14492-2
- DIN 15400 (load hook)
- FEM calculation regulations for series lifting equipment (chain drive, motor, full load-life span)
- ISO 4301-1: D (M3) = 400 h
- Remarks about general revision (see chapter 4)

There is differing coefficient data for the ISO Groups that must be adhered to in operation.



CAUTION !

The travelling gear is always classified as the same ISO Group as the corresponding electric chain hoist.



NOTE

The ISO Group registration number of the electric chain hoist can be found on the data plate.

The manufacturer will only guarantee the safety and lasting operation of the electric chain hoist when used for applications that fall within its valid ISO Group coefficient data.

Before the first start-up, the user must estimate according to the features in table 1-1, which of the four types of load is applicable to the use of the electric chain hoist during its whole service life. Table 1-2 shows standard values for the operating conditions of the ISO Groups depending on the type of load and the time of operation.

Ascertaining the correct type of application for an electric chain hoist:

Either the running time or expected type of load can be used as a basis for ascertaining the correct type of application for the electric chain hoist.



CAUTION !

Before starting up the electric chain hoist for the first time, it must be determined with which of the load types shown in table 1-1 the electric chain hoist is to operate. Assignment to a load type or a load collective (k) applies for the entire operational life of the equipment and may not be altered for operational safety reasons.

Example 1: Ascertaining permissible running time of the electric chain hoist:

An electric chain hoist of the ISO Group M4 is to be used for medium stress load tasks throughout its entire service life. This corresponds to load type <3 heavy> (see table 1-1). According to the values in table 1-2, the electric chain hoist should not be used for longer than 0.5 - 1 hour per working day.

Example 2: Ascertaining permissible load type:

An electric chain hoist of the ISO Group M5 is to be used for approximately 6 hours per working day, throughout its complete service life. Consequently the electric chain hoist should be operated in accordance with the characteristics of the load type <1 light> (see table 1-1).

Table 1-1 Load collectives

Load type 1 light $k < 0.50$ $k = 0.50$	Load type 2 medium $0.50 < k < 0.63$ $k = 0.63$	Load type 3 heavy $0.63 < k < 0.80$ $k = 0.80$	Load type 4 very heavy $0.80 < k < 1.00$ $k = 1.00$
<p>% of bearing capacity</p> <p>% of running time</p> <p>Full load by way of an exception, however, predominantly low loads</p>	<p>% of bearing capacity</p> <p>% of running time</p> <p>Frequently fully loaded, however continuously lightly loaded</p>	<p>% of bearing capacity</p> <p>% of running time</p> <p>Frequently fully loaded, continuous average loading</p>	<p>% of bearing capacity</p> <p>% of running time</p> <p>Regularly fully loaded</p>

k = Load collective (type of load)

Table 1-2 Operating conditions

ISO Group according to ISO 4301-1	M3	M4	M5	M6	M7
Load collective	Average running time per working day [h]				
1 - light $k < 0.50$	up to 2	2 - 4	4 - 8	8 - 16	over 16
2 - medium $0.50 < k < 0.63$	up to 1	1 - 2	2 - 4	4 - 8	8 - 16
3 - heavy $0.63 < k < 0.80$	up to 0.5	0.5 - 1	1 - 2	2 - 4	4 - 8
4 - very heavy $0.80 < k < 1.00$	up to 0.25	up to 0.5	0.5 - 1	1 - 2	2 - 4

1.2 General description

Figure 1-1

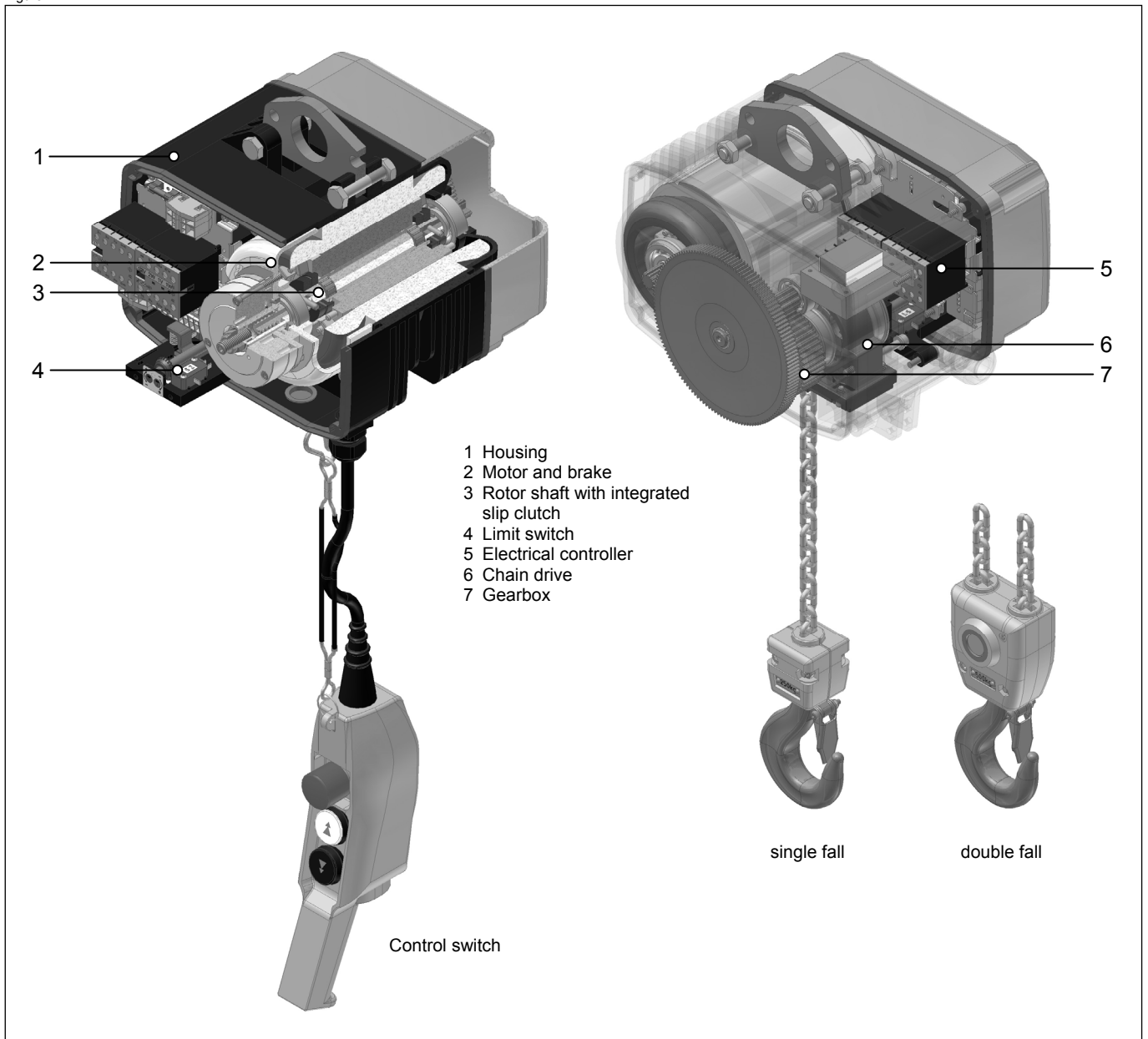

The electric chain hoist meets the requirements of the EC Machinery Directive and the relevant EN and FEM standards.

Housing and cover are made of a sturdy aluminum die casting. Fins on the motor ensure optimum cooling. The chain box can be attached to the compactly constructed housing. A drilled hole is provided for both the power supply cable gland and the control cable. The lugs, or optionally the suspension hooks, are attached to the flange ring. GIS electric chain hoists are driven by asynchronous motors. For two-speed models a pole switching version of the motor is fitted.

The braking system consists of a DC-operated spring loaded brake. When there is no current, the pressure spring generates the braking torque.

For functional reasons, the slip clutch is installed in front of the brake system and integrated into the rotor shaft. It protects the hoist from overload and takes on the function of an emergency end stop for the highest and lowest hook positions.

A gear-type limit switch is fitted to limit the highest and lowest hook position. As an option, emergency stop contacts with positive separation can be retrofitted downstream. Electric chain hoists are fitted with a 42 V contactor control as standard. The emergency stop contactor that is usually installed separates all three mains power phases when the red button is pressed.

The high-strength round steel chain meets the requirements of grade DAT (8SS) to DIN EN 818-7. Sprocket and pulley are hardened. The load hook, which complies with DIN 15400, is fitted with a safety latch.

The two- or three-stage, closed spur gear units are usually helically cut. The gears are mounted on roller bearings and run greased.

The standard equipment fitted to the electric chain hoist includes a control switch (up/down with emergency stop).

1.3 Special models

Figure 1-2

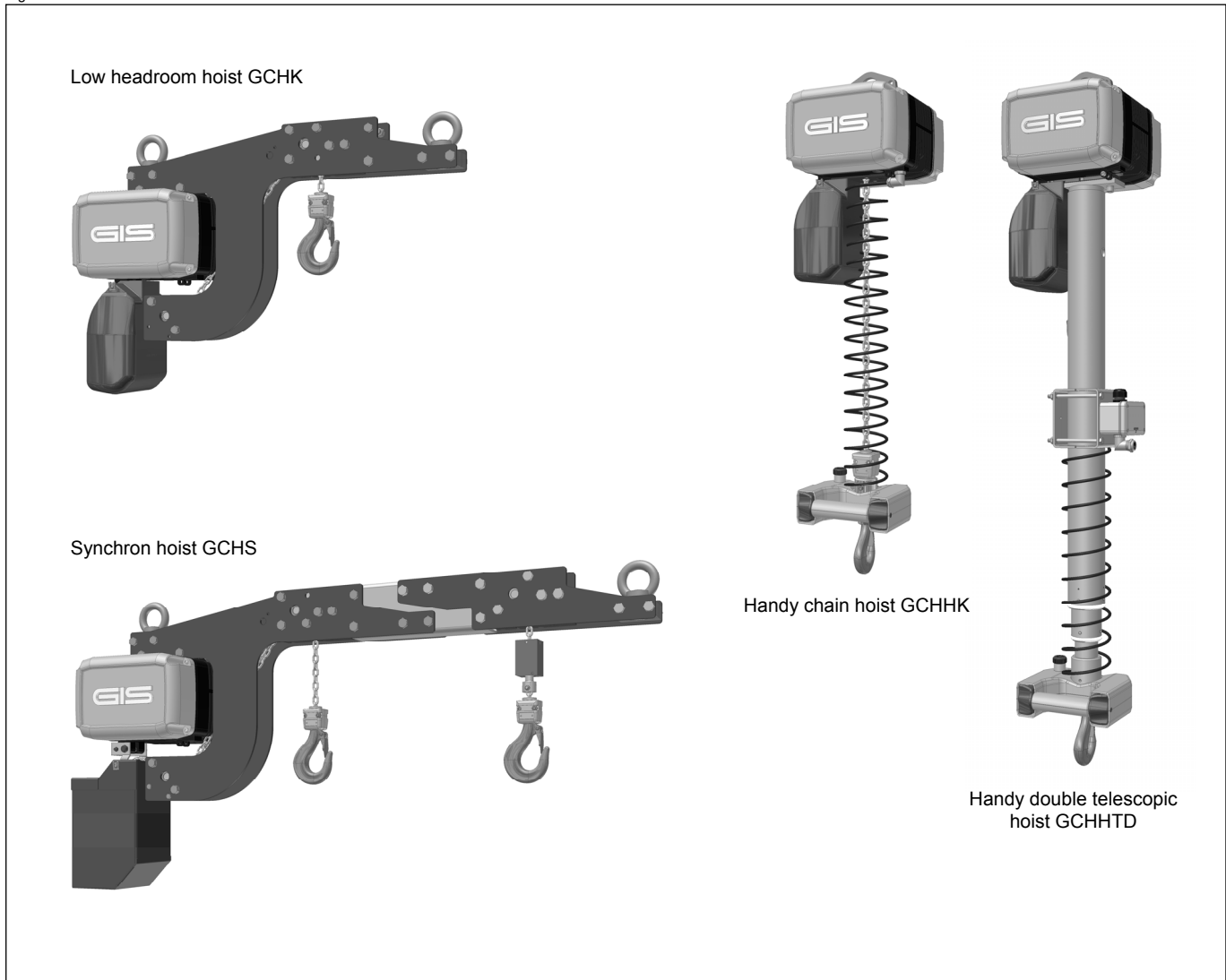

2 Start-up



DANGER !

Mechanical adjustments may only be performed by authorised specialists.



CAUTION !

Operating staff must carefully read the operating instructions of the electric chain hoists before its initial operation and carry out all checks. Only when safe operation has been established may the device be put into operation. Unauthorised persons may not operate the device or carry out work with it.

2.1 Transport and assembly

The safety directions for handling with loads should be followed (see chapter 0.3) when transporting and assembling the electric chain hoist.

Electric chain hoists must be assembled by qualified staff, always bearing in mind the accident prevention directions in chapter 0.2. Before assembly the electric chain hoist must be stored in an enclosed room or covered area.

Should the electric chain hoist be destined for operation outdoors, then it is recommended that a protection cover is erected to shield it from the effects of the weather.

Wherever possible, the electric chain hoist should be transported in its original packaging. The goods delivered should be checked for completeness and the packaging disposed of in an environmentally sound manner. It is recommended that the electric chain hoist is assembled and connected on-site by our qualified customer service personnel.

2.2 Connection

2.2.1 Electrical connection



DANGER !

Electrotechnical adjustments may only be performed by authorised specialists.

The mains connection cable, the mains connection fuse and the main switch for connecting the electric chain hoist to the mains power supply must be installed beforehand by the customer.

A 4-wire cable with a PE protective conductor is needed to provide the power supply for three-phase models. A 3-wire cable with a protective conductor is adequate for single-phase models. The length and cross-section must be appropriate for the power consumption of the electric chain hoist.

- Before connecting the electric chain hoist, check whether the operating voltage and frequency that are specified on the name plate correspond to the available power supply
- Remove cover on electrical side
- Insert connecting cable with M25 x 1.5 screwed cable connection into hole at side and connect to terminals L1, L2, L3 and PE in accordance with supplied circuit diagram (see figure 2-1)
- Insert control cable with M20 x 1.5 screwed cable connection through hole in underside of housing and connect to terminals 1, 2, 3, 4 and 10 (see figure 2-2)
- Attach strain relief to housing (see figure 2-3)



CAUTION !

The control switch must be attached to the strain relief cord and not to the cable.

Figure 2-1

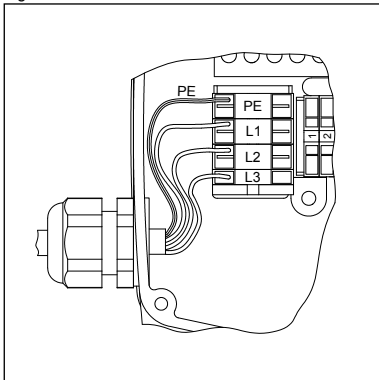

Figure 2-2

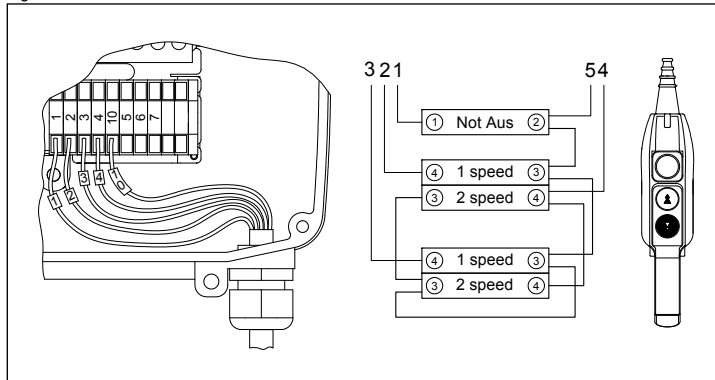
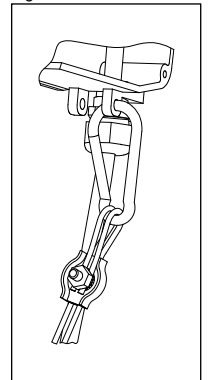

Figure 2-3



**DANGER !**

The protective conductor should not carry any power. With motor carriage operation, the power supply is enclosed in a terminal box of the drive motor. With the installation of a motor protector, the load plate voltage of the electric chain hoist must be observed.

**CAUTION !**

- Checking direction of rotation: If the direction of rotation does not correspond to the button symbols on the control switch, power supply wires L1 and L2 must be swapped round
- Inching operations on single-phase models can cause interference

**NOTE**

Open the terminal that is used in accordance with figure 2-4.

Figure 2-4

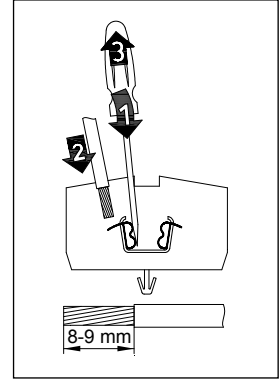

2.2.2 Load chain

**CAUTION !**

- Only use original chains
- Welded seam of the chain links must face inward on the chain wheel (see figure 2-5)
- The gearbox limit switch must be mechanically disabled in order to pull in the chain, see chapter 2.2.3

Before start-up and during operation the load chain must be oiled along its full length. Oil must constantly be present on the internal, contacting and rubbing surfaces of the chain links. Lubrication is carried out by submersion or with an oil can, using a creeping gear oil.

The end of the chain should be attached to a flexible piece of wire (1) and fed through the chain wheel (2) of the electric chain hoist. Through short switching impulses, the chain (3) will be housed correctly in accordance with figure 2-5.

The lifting height must be adjusted such that the hook fittings lie on the ground in the lowest hook position.

Figure 2-5

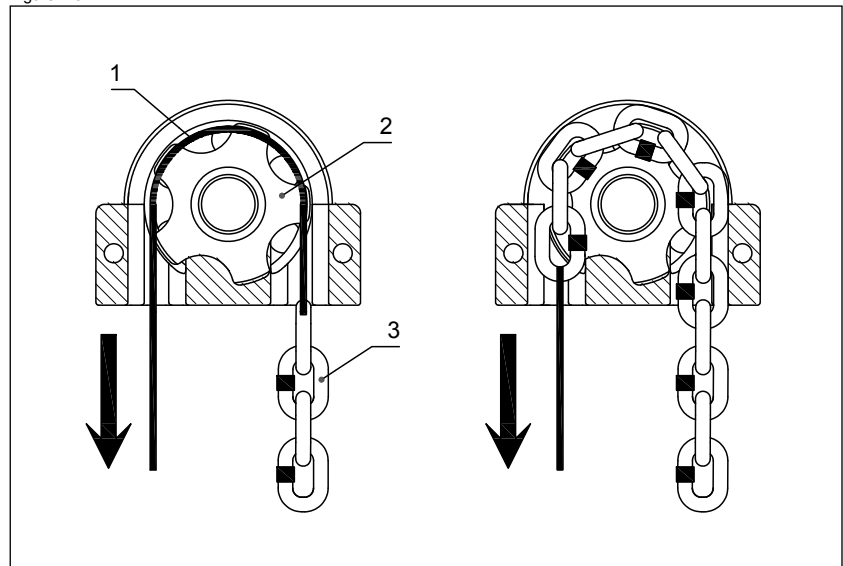

Single fall operation: The load hook (1) is connected to the chain using a shim (2). Bolt (3) installation is important for power transmission (see figure 2-6).



CAUTION !
Pay attention to correct arrangement of suspension (see figure 2-7)! Grease the bearings thoroughly.

Figure 2-6

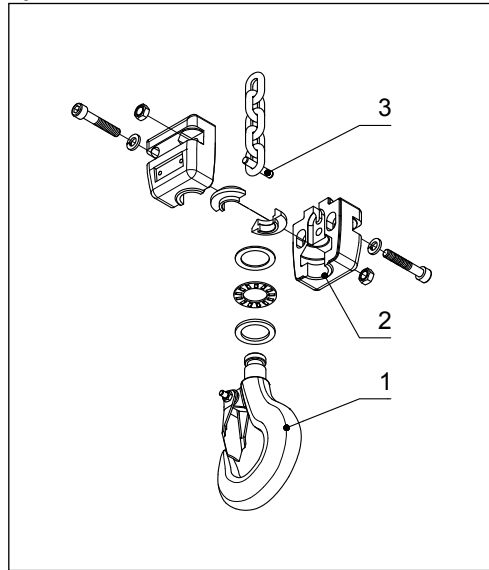

Figure 2-7

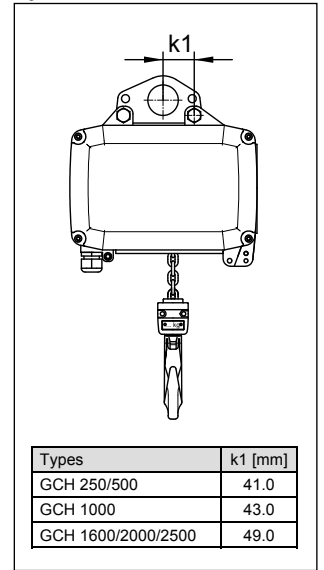
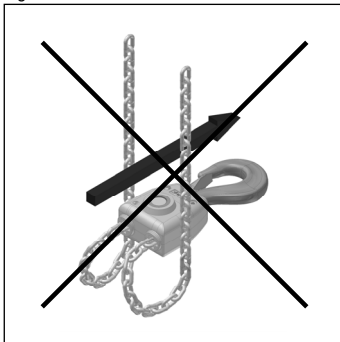

Figure 2-8



Double fall operation: Connect load side of chain end to chain retainer (3) and fix in housing guide rail. Assemble bottom sheave (1) with load hook (2) in accordance with figure 2-9.



CAUTION !
Pay attention to correct arrangement of suspension (see figure 2-10)! Do not twist chain lengthwise (see figure 2-8)! Grease the bearings thoroughly.

Chain end: The chain end must be attached to the housing in accordance with figure 2-11.

The section of chain after the end stop (1) must be adjusted to the height of the chain bucket. The length of the section of chain must be selected so that the end stop lies on the floor of the magazine when the chain runs into it (see figure 2-11).

Figure 2-9

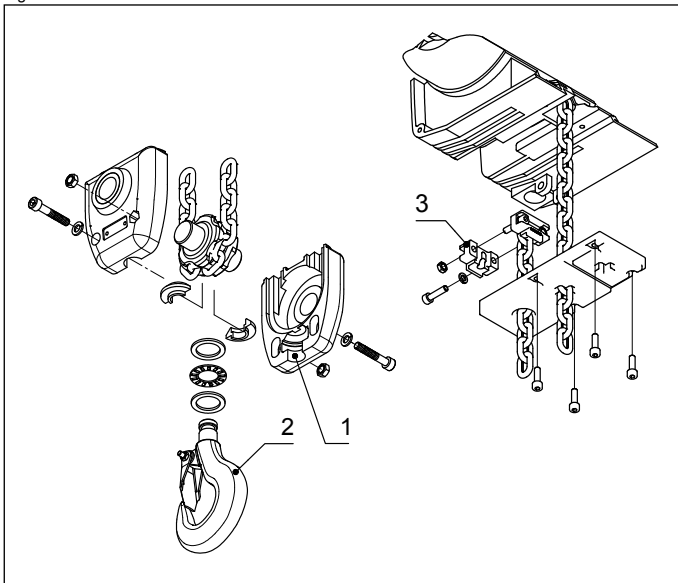

Figure 2-10

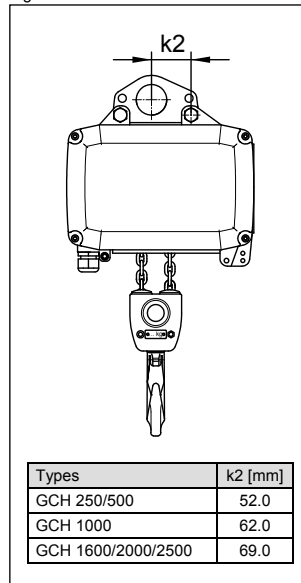
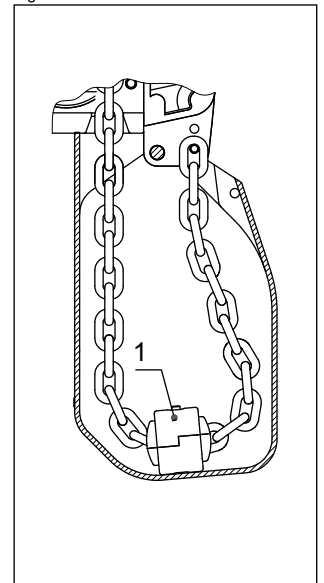

Figure 2-11



2.2.3 Limit switch

The electric chain hoist is equipped with a gearbox limit switch as standard. This is also suitable for normal limit switch operation with a high degree of accuracy. The operation of the limit switches (highest and lowest hook position) must be checked during start-up.

Three different transmissions are available that are adapted to the lift:

GCH 250/500			
Transmission	Colour	Single fall lift [m]	Double fall lift [m]
i = 1:1	black	20	10
i = 1:3	yellow	60	30
i = 1:6	blue	120	60

GCH 1000			
Transmission	Colour	Single fall lift [m]	Double fall lift [m]
i = 1:1	black	30	15
i = 1:3	yellow	80	40
i = 1:6	blue	180	90

GCH 1600/2000/2500			
Transmission	Colour	Single fall lift [m]	Double fall lift [m]
i = 1:1	black	36	18
i = 1:3	yellow	110	55
i = 1:6	blue	220	110

Description of settings (see figure 2-12):

- Before pulling in the chain or changing the chain, the gearbox limit switch must be mechanically disabled by securing the rocker (1)
- Pull in the chain
- Move to highest hook position, rotate red ratchet wheel (front) (2) to switching cam of top limit switch (3); (rotate clockwise for higher hook position and anticlockwise for lower hook position)
- Activate rocker, move to lowest hook position, rotate green switching wheel (rear) (4) to switching cam of bottom limit switch (5); (rotate anticlockwise for higher hook position and clockwise for lower hook position)
- Activate rocker (must engage in switch wheel)
- Check operation of limit switch; the end stop and the hook fittings must not touch the housing

Figure 2-12

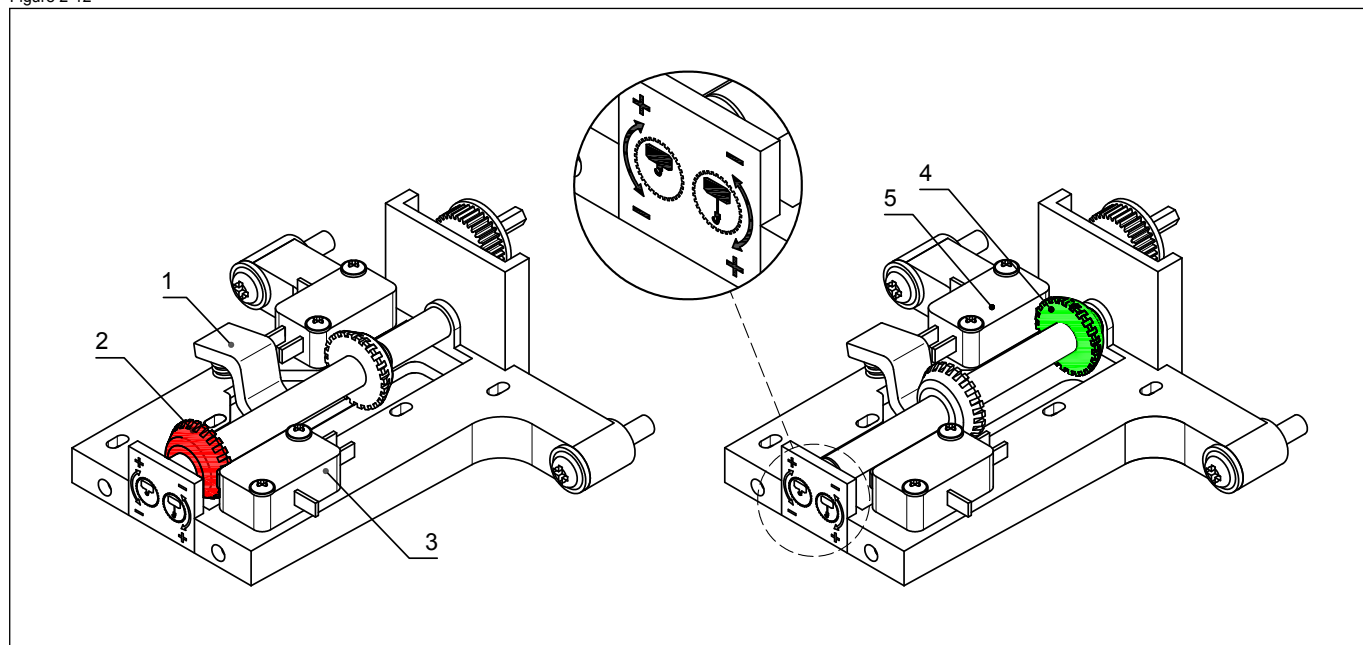

2.2.4 Chain bucket

- Move chain out at load side until limit switch is activated
- Attach free end of chain to housing (see chapter 2.2.2)
- Attach chain bucket and allow chain to run in (see figure 2-13)



DANGER !

All steel plate chain buckets must be equipped with an additional wire cable with a minimum diameter of 2 mm (see figure 2-14).

Figure 2-13

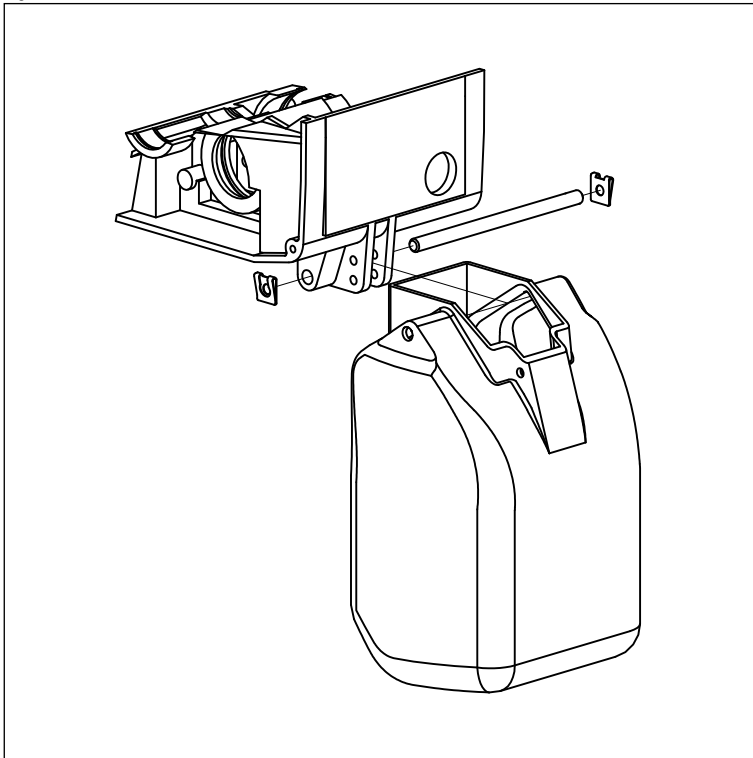
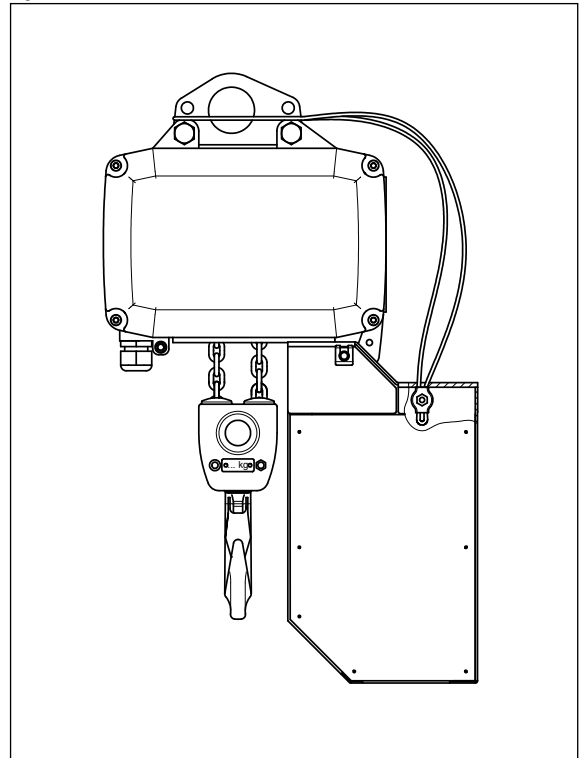

Figure 2-14



3 Service and maintenance

3.1 General regulations for service and maintenance work

Operating failures in electric chain hoists affecting the safe operation of the device should be remedied immediately.



CAUTION !

Maintenance and repair work on the electric chain hoist may only be carried out by qualified and trained personnel.



CAUTION !

If the operator performs maintenance work on an electric chain hoist on his own account, the type of maintenance performed together with the date carried out must be entered in the log book.

Alterations to, as well as modifications and supplements to electric chain hoists which may affect safety must be authorized by the manufacturer in advance. Structural alterations to chain hoists not authorized by the manufacturer exempt the manufacturer from liability in case of damage.

Material warranty claims will only be recognized if solely manufacturer's genuine spare parts have been used.

We explicitly wish to point out that those original parts and accessories not supplied on our behalf cannot be inspected or released by us.

General:

Service and maintenance are preventive measures designed to preserve the full functionality of electric chain hoists. Non-compliance with service and maintenance routines can result in reduction in the useful function of and/ or damage to electric chain hoists.

Service and maintenance work should be carried out at the predefined time intervals, in accordance with the instruction manual (table 3-1 and 3-2).

During service and maintenance work, general accident prevention directions, special safety directions (chapter 0.3) as well as hazard protection instructions (chapter 0.4) should be followed.



DANGER !

Service and maintenance work should only be performed on unloaded electric chain hoists. The main switch must be off. The lower sheave or hook fittings must be lying on the floor or a maintenance platform.

Maintenance work encompasses visual checks and cleaning routines. Service work includes additional functional checks. During the functional checks, all securing elements and cable clamps must be checked for secure seating. Cables must be inspected for dirt, discoloration and arc spots.



CAUTION !

Used operating materials (oil, lubricants, etc.) should be safely collected and disposed of in an environmentally friendly manner.

Service and maintenance intervals are defined as follows:

- t : daily
- 3 M : quarterly
- 12 M : annually

The predefined service and maintenance intervals should be reduced when the loading of the electric chain hoist is exceptionally large and when frequently operated in adverse conditions (dust, heat, humidity, steam, etc.).

3.2 Service and maintenance

3.2.1 Maintenance overview

See table 3-1.

Table 3-1 Maintenance overview

Term	t	3 M	12 M	Activity	Notes
1. Load chain	X			visual check clean and lubricate as needed	see chapter 2.2.2
2. Hoist and carriage	X			abnormal noise check seal check	
3. Power supply cable	X			visual check	
4. Limit switch	X			function check	see chapter 2.2.3
5. Seal		X		visual check	
6. Cable discharging device control cable	X			visual check	

3.2.2 Service overview

See table 3-2.

Table 3-2 Service overview

Term	t	3 M	12 M	Activity	Notes
1. Load chain		X	X	lubricate measure wear	see chapter 2.2.2 / 3.2.4
2. Brake system	X		X	function check with load	see chapter 3.2.3
3. Electrical fittings			X	function check	
4. Securing screws on suspended parts and load hook with accessories			X	check for cracks check screw movement	see chapter 3.2.8
5. Gearing			X	visual check wear	see chapter 3.2.6
6. Limit switch			X	check switching elements	see chapter 2.2.3
7. Slip clutch			X	function check	see chapter 3.2.7

3.2.3 Brake system

The spring-loaded brake is a solenoid operated single disk brake with two friction surfaces. The braking force is applied by compression springs. The braking torque is generated when no current is applied. The ventilation is electromagnetic. The brake operates with DC current.

The brake must be able to hold the nominal load in power free mode without any problems.



CAUTION !

The brake coil voltage must be the same as the operating voltage.

**NOTE**

The brake has no air gap adjustment. If the air gap (a_{max} , table 3-3 and figure 3-1) reaches maximal value, the brake pad needs changing.

Table 3-3 Air gap

	GCH 250/500	GCH 1000	GCH 1600/2000/2500
Air gap (a) [mm]	0.4 $\begin{matrix} +0.15 \\ 0 \end{matrix}$	0.5 $\begin{matrix} +0.2 \\ 0 \end{matrix}$	0.5 $\begin{matrix} +0.2 \\ 0 \end{matrix}$
Air gap (a_{max}) [mm]	0.7	0.9	0.9
Torque value [Nm]	3	10	10

Figure 3-1

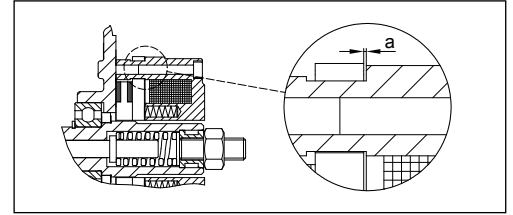

3.2.4 Load chain

The load chain should be periodically checked for abrasion. The check is based upon three measurements: see accepted wear factors (table 3-4) and measurement points (figure 3-2).

**CAUTION !**

The chain should be replaced when the measurements exceed or fall short of those defined in the table. The chain wheel and chain guide should be checked for wear at the same time and, where necessary, be replaced. Only use original chains. The chain links should not be welded.

The new chain is installed in accordance with chapter 2.2.2.

**NOTE**

For ease of installation, the old chain and new chain can be connected by a piece of flexible wire.

Table 3-4 Wear factors load chain

	GCH 250	GCH 500	GCH 1000	GCH 1600	GCH 2000/2500
Chain type d x t [mm]	4 x 12.3	5 x 15.3	7 x 22	9 x 27	10 x 28
Tolerances in accordance with: DIN 685, part 5 DIN EN 818-7					
1. Measurement over 11 chain links; $a = 11t$ [mm]	138.0	171.6	246.8	302.9	314.2
2. Measurement over 1 chain link $1t$ [mm]	12.9	16.0	23.1	28.35	29.4
3. Measurement of the chain link diameter $dm = \frac{d1 + d2}{2}$; (dm min. = 0.9 x d) [mm]	3.6	4.5	6.3	8.1	9.0

Figure 3-2

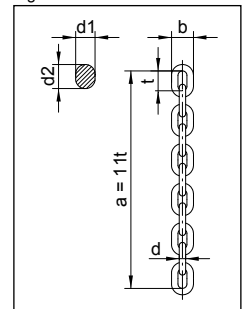

3.2.5 Limit stop assembly

**CAUTION !**

A damaged buffer plate, underneath the housing, must be replaced.

Screw connections at the limit stop and shims or lower sheaves should be checked and, where necessary, tightened to the right torque. For coefficient data see chapter 3.2.8.

3.2.6 Gearbox

The gearing has continual lubrication.

Lubricant.....: Strub N1424

Can be mixed and is compatible with all other similar brand name grease (DIN 51502: GP OM-20)

Lubricant quantity: GCH 250/500: 0.4 kg

GCH 1000: 1.0 kg

GCH 1600/2000/2500: 1.8 kg

3.2.7 Slip clutch

The slip clutch is set at 125% at the factory and can be relied on to prevent the chain hoist from being overloaded (the force limiting factor according to DIN EN 14492-2 is $\Phi_{DAL} = 1.4$). The coating is wear resistant.

**CAUTION !**

Adjustment and testing of the slip clutch may only be carried out by authorized personnel and must be recorded in the log book.

3.2.8 Suspension parts

All statically loaded parts are considered suspension parts. The bearing surfaces of the slewing suspension parts must be periodically greased.
Torque values for screws of property class 8.8 according to DIN ISO 898:

M 5	M 6	M 8	M 10	M 12
6 Nm	10 Nm	24 Nm	48 Nm	83 Nm

3.3 Ordering spare parts

Information on how to order spare parts can be found on page 3.

4 Measures for obtaining a safe period of operation

The statutory and health requirements of the EU regulations stipulate that specific dangers which may arise from fatigue or ageing must be prevented. Accordingly, operators of standard hoist gear are obliged to determine the actual utilization. The actual utilization period is determined and recorded as part of the annual inspection by customer service engineers. A general overhaul must be carried out when the theoretical utilization limit is reached, or after no more than 10 years. All checking and the general overhaul itself must be arranged by the operator of the hoist gear. The following theoretical utilization periods apply to electric chain hoists that are categorized according to ISO 4301-1 (converted into full-load hours):

M3	M4	M5	M6	M7
400 h	800 h	1600 h	3200 h	6300 h

4.1 Determining the actual utilization period S

The actual utilization period depends on the daily operating time and the load collective. Running time is determined from information provided by the operator or recorded using a meter that counts the number of operating hours. The load collective is determined in accordance with table 1-1, page 9. These two items of information are used to calculate the annual utilization period from table 4-1.

If an operating data acquisition system (BDE) is used, the actual utilization can be read out directly by our experts during the annual inspection.



CAUTION !

The values periodically calculated or read-off must be recorded in the log book.

4.2 General overhaul

On reaching the theoretical service life (no later than 10 years for recording without BDE), a general overhaul should be performed. This enables the equipment to continue operating safely for a further period of utilization (service life). Components must be inspected and/ or replaced in this overhaul according to table 4-2. Inspection and approval for further use must be performed either by a specialist company authorized by the manufacturer, or by the manufacturer personally.

The inspector determines: – the new theoretical utilization possible
– the maximum period until the next general overhaul

This data should be recorded in the log book.

Table 4-1 Annual service life

Utilization per day [h]	<= 0.25 (0.16)	<= 0.50 (0.32)	<= 1.0 (0.64)	<= 2.0 (1.28)	<= 4.0 (2.56)	<= 8.0 (5.12)	<= 16.0 (10.24)	> 16.0 (20.48)
Load collective	Annual service life [h]							
k = 0.50	6	12	24	48	96	192	384	768
k = 0.63	12	24	48	96	192	384	768	1536
k = 0.80	24	48	96	192	384	768	1536	3072
k = 1.00	48	96	192	384	768	1536	3072	6144

Table 4-2 General overhaul

Components of GCH-models all types	Check for wear *	Replace
Brake	x	
Motor shaft	x	
Gear teeth		x
Antifriction bearing		x
Washers		x
Chain	x **	
Chain wheel, chain guide	x	
Deflection wheels	x	
Suspension	x	
Load hook		x
Travelling gear, running wheel	x	
Contactors, limit switch	x	

* replace when worn

** replace no later than at general overhaul

5 Appendix

Table 0-2 GCH technical data

ISO (FEM) classification	M3 (1Bm) 150 s/h 25% duty	M4 (1Am) 180 s/h 30% duty	M5 (2m) 240 s/h 40% duty	M6 (3m) 300 s/h 50% duty	M7 (4m) 360 s/h 60% duty	Lifting speed	Motor power (M3)	3 x 400V 50Hz (M3)	1 x 230V 50Hz (M3)	No. of chain falls	Dead weight 3 m lift	Connection fuse
Types	Capacity [kg]					[m/min]	[kW]	[A]	[A]		[kg]	[A]
GCH 250/1N	250	200	160	125	100	8	0.36	1.3	-	1	19	10
GCH 250/1NF	250	200	160	125	100	8/2	0.36/0.09	2.7/3.0	-	1	22	10
GCH 250/1SF	160	125	100	100	100	12.5/3	0.36/0.09	2.7/3.0	-	1	22	10
GCH 250/1HF	100	100	100	100	100	20/5	0.36/0.09	2.7/3.0	-	1	22	10
GCH 250/1N 1Ph	160	-	-	-	-	8	0.23	-	8.9	1	19	10
GCH 250/2N	500	400	320	250	200	4	0.36	1.3	-	2	22.5	10
GCH 250/2NF	500	400	320	250	200	4/1	0.36/0.09	2.7/3.0	-	2	23	10
GCH 250/2SF	320	250	200	200	200	6.25/1.5	0.36/0.09	2.7/3.0	-	2	23	10
GCH 250/2N 1Ph	320	-	-	-	-	4	0.23	-	8.9	2	22.5	10
GCH 500/1N	500	400	320	250	200	8	0.72	2.1	-	1	20	10
GCH 500/1NF	500	400	320	250	200	8/2	0.72/0.18	2.9/3.0	-	1	22.5	10
GCH 500/1SF	320	250	200	160	125	12.5/3	0.72/0.18	2.9/3.0	-	1	22.5	10
GCH 500/1HF	200	160	125	100	100	20/5	0.72/0.18	2.9/3.0	-	1	22.5	10
GCH 500/1N 1Ph	250	-	-	-	-	8	0.36	-	8.9	1	20	10
GCH 500/2N	1,000	800	630	500	400	4	0.72	2.1	-	2	24.5	10
GCH 500/2NF	1,000	800	630	500	400	4/1	0.72/0.18	2.9/3.0	-	2	25	10
GCH 500/2SF	630	500	400	320	250	6.25/1.5	0.72/0.18	2.9/3.0	-	2	25	10
GCH 500/2N 1Ph	500	-	-	-	-	4	0.36	-	8.9	2	24.5	10
GCH 1000/1N	1,000	800	630	500	400	8	1.45	3.7	-	1	45	10
GCH 1000/1NF	1,000	800	630	500	400	8/2	1.45/0.36	4.0/2.8	-	1	46	10
GCH 1000/1SF	500	400	320	250	200	16/4	1.45/0.36	5.8/2.6	-	1	48	10
GCH 1000/1N 1Ph	500	-	-	-	-	8	0.73	-	6.0	1	46	10
GCH 1000/2N	2,000	1,600	1,250	1,000	800	4	1.45	3.7	-	2	50	10
GCH 1000/2NF	2,000	1,600	1,250	1,000	800	4/1	1.45/0.36	4.0/2.8	-	2	51	10
GCH 1000/2SF	1,000	800	630	500	400	8/2	1.45/0.36	5.8/2.6	-	2	53	10
GCH 1000/2N 1Ph	1,000	-	-	-	-	4	0.73	-	6.0	2	51	10
GCH 1600/1N	1,600	1,250	1,000	800	630	8	2.44	6.0	-	1	63	16
GCH 1600/1NF	1,600	1,250	1,000	800	630	8/2	2.44/0.61	6.6/4.2	-	1	65	16
GCH 1600/1SF	1,000	800	630	500	400	12.5/3	2.39/0.58	6.6/4.2	-	1	65	16
GCH 1600/2N	3,200	2,500	2,000	1,600	1,250	4	2.44	6.0	-	2	73	16
GCH 1600/2NF	3,200	2,500	2,000	1,600	1,250	4/1	2.44/0.61	6.6/4.2	-	2	75	16
GCH 1600/2SF	2,000	1,600	1,250	1,000	800	6.25/1.5	2.39/0.58	6.6/4.2	-	2	75	16
GCH 2000/1N	2,000	1,600	1,250	1,000	800	8	3.05	7.3	-	1	65	16
GCH 2000/1NF	2,000	1,600	1,250	1,000	800	8/2	3.05/0.77	8.0/4.5	-	1	67	16
GCH 2000/1SF	1,250	1,000	800	630	500	12.5/3	2.98/0.72	8.0/4.5	-	1	67	16
GCH 2000/2N	4,000	3,200	2,500	2,000	1,600	4	3.05	7.3	-	2	76	16
GCH 2000/2NF	4,000	3,200	2,500	2,000	1,600	4/1	3.05/0.77	8.0/4.5	-	2	78	16
GCH 2000/2SF	2,500	2,000	1,600	1,250	1,000	6.25/1.5	2.98/0.72	8.0/4.5	-	2	78	16
GCH 2500/1N	2,500	2,000	1,600	1,250	1,000	6.4	3.05	7.7	-	1	65	16
GCH 2500/1NF	2,500	2,000	1,600	1,250	1,000	6.4/1.6	3.05/0.77	8.2/4.4	-	1	67	16
GCH 2500/1SF	1,600	1,250	1,000	800	630	10/2.5	3.05/0.77	8.2/4.4	-	1	67	16
GCH 2500/2N	5,000	4,000	3,200	2,500	2,000	3.2	3.05	7.7	-	2	76	16
GCH 2500/2NF	5,000	4,000	3,200	2,500	2,000	3.2/0.8	3.05/0.77	8.2/4.4	-	2	78	16
GCH 2500/2SF	3,200	2,500	2,000	1,600	1,250	5/1.25	3.05/0.77	8.2/4.4	-	2	78	16

Table 0-3 GCHK technical data

ISO (FEM) classification	M3 (1Bm) 150 s/h 25% duty	M4 (1Am) 180 s/h 30% duty	M5 (2m) 240 s/h 40% duty	M6 (3m) 300 s/h 50% duty	M7 (4m) 360 s/h 60% duty	Lifting speed	Motor power (M3)	3 x 400V 50Hz (M3)	1 x 230V 50Hz (M3)	No. of chain falls	Dead weight 3 m lift	Connection fuse
Types	Capacity [kg]					[m/min]	[kW]	[A]	[A]		[kg]	[A]
GCHK 250/1NF	200	160	125	100	100	8/2	0.29/0.07	2.7/3.0	-	1	40	10
GCHK 250/1SF	125	100	100	100	100	12.5/3	0.28/0.07	2.7/3.0	-	1	40	10
GCHK 250/2NF	400	320	250	200	200	4/1	0.29/0.07	2.7/3.0	-	2	41	10
GCHK 250/2SF	250	200	200	200	200	6.25/1.5	0.28/0.07	2.7/3.0	-	2	41	10
GCHK 500/1NF	400	320	250	200	160	8/2	0.58/0.14	2.9/3.0	-	1	40.5	10
GCHK 500/1SF	250	200	160	125	100	12.5/3	0.57/0.14	2.9/3.0	-	1	40.5	10
GCHK 500/2NF	800	630	500	400	320	4/1	0.58/0.14	2.9/3.0	-	2	43	10
GCHK 500/2SF	500	400	320	250	200	6.25/1.5	0.57/0.14	2.9/3.0	-	2	43	10
GCHK 1000/1NF	800	630	500	400	320	8/2	1.16/0.29	3.3/2.8	-	1	88	10
GCHK 1000/1SF	400	320	250	200	160	16/4	1.16/0.29	5.4/2.4	-	1	90	10
GCHK 1000/2NF	1,600	1,250	1,000	800	630	4/1	1.16/0.29	3.3/2.8	-	2	94	10
GCHK 1000/2SF	800	630	500	400	320	8/2	1.16/0.29	5.4/2.4	-	2	96	10
GCHK 1600/1NF	1,250	1,000	800	630	500	8/2	1.91/0.48	5.5/4.1	-	1	127	16
GCHK 1600/1SF	800	630	500	400	320	12.5/3	1.91/0.48	5.5/4.1	-	1	127	16
GCHK 1600/2NF	2,500	2,000	1,600	1,250	1,000	4/1	1.91/0.48	5.5/4.1	-	2	139	16
GCHK 1600/2SF	1,600	1,250	1,000	800	630	6.25/1.5	1.91/0.48	5.5/4.1	-	2	139	16
GCHK 2000/1NF	1,600	1,250	1,000	800	630	8/2	2.44/0.61	6.6/4.2	-	1	129	16
GCHK 2000/1SF	1,000	800	630	500	400	12.5/3	2.38/0.57	6.6/4.2	-	1	129	16
GCHK 2000/2NF	3,200	2,500	2,000	1,600	1,250	4/1	2.44/0.61	6.6/4.2	-	2	142	16
GCHK 2000/2SF	2,000	1,600	1,250	1,000	800	6.25/1.5	2.38/0.57	6.6/4.2	-	2	142	16
GCHK 2500/1NF	2,000	1,600	1,250	1,000	800	6.4/1.6	2.44/0.61	6.2/4.1	-	1	129	16
GCHK 2500/1SF	1,250	1,000	800	630	500	10/2.5	2.38/0.60	6.2/4.1	-	1	129	16
GCHK 2500/2NF	4,000	3,200	2,500	2,000	1,600	3.2/0.8	2.44/0.61	6.2/4.1	-	2	142	16
GCHK 2500/2SF	2,500	2,000	1,600	1,250	1,000	5/1.25	2.38/0.60	6.2/4.1	-	2	142	16

Table 0-4 GCHS technical data

ISO (FEM) classification	M3 (1Bm) 150 s/h 25% duty	M4 (1Am) 180 s/h 30% duty	M5 (2m) 240 s/h 40% duty	M6 (3m) 300 s/h 50% duty	M7 (4m) 360 s/h 60% duty	Lifting speed	Motor power (M3)	3 x 400V 50Hz (M3)	1 x 230V 50Hz (M3)	No. of chain falls	Dead weight 3 m lift	Connection fuse
Types	Capacity [kg]					[m/min]	[kW]	[A]	[A]		[kg]	[A]
GCHS 500/1NF GCHS 500/1SF	2x200 2x125	2x160 2x100	2x125 2x80	2x100 2x60	2x80 2x50	8/2 12.5/3	0.58/0.14 0.57/0.14	2.9/3.0 2.9/3.0	- -	1 1	44.5 44.5	10 10
GCHS 500/2NF GCHS 500/2SF	2x400 2x250	2x320 2x200	2x250 2x160	2x200 2x125	2x160 2x100	4/1 6.25/1.5	0.58/0.14 0.57/0.14	2.9/3.0 2.9/3.0	- -	2 2	47 47	10 10
GCHS 1000/1NF GCHS 1000/1SF	2x400 2x200	2x320 2x160	2x250 2x125	2x200 2x100	2x160 2x80	8/2 16/4	1.16/0.29 1.16/0.29	3.3/2.8 5.4/2.4	- -	1 1	87 89	10 10
GCHS 1000/2NF GCHS 1000/2SF	2x800 2x400	2x630 2x320	2x500 2x250	2x400 2x200	2x320 2x160	4/1 8/2	1.16/0.29 1.16/0.29	3.3/2.8 5.4/2.4	- -	2 2	93 95	10 10
GCHS 2000/1NF GCHS 2000/1SF	2x800 2x500	2x630 2x400	2x500 2x320	2x400 2x250	2x320 2x200	8/2 12.5/3	2.44/0.61 2.38/0.57	6.6/4.2 6.6/4.2	- -	1 1	151 151	16 16
GCHS 2000/2NF GCHS 2000/2SF	2x1'600 2x1'000	2x1'250 2x800	2x1'000 2x630	2x800 2x500	2x630 2x400	4/1 6.25/1.5	2.44/0.61 2.38/0.57	6.6/4.2 6.6/4.2	- -	2 2	168 168	16 16

Table 0-5 GCHHK technical data

ISO (FEM) classification	M3 (1Bm) 150 s/h 25% duty	M4 (1Am) 180 s/h 30% duty	M5 (2m) 240 s/h 40% duty	M6 (3m) 300 s/h 50% duty	M7 (4m) 360 s/h 60% duty	Lifting speed	Motor power (M5)	3 x 400V 50Hz (M5)	1 x 230V 50Hz (M5)	No. of chain falls	Dead weight 3 m lift	Connection fuse
Types	Capacity [kg]					[m/min]	[kW]	[A]	[A]		[kg]	[A]
GCHHK 500/NF GCHHK 500/SF GCHHK 500/HF	- - -	- - -	250 200 125	250 160 100	200 125 100	8/2 12.5/3 20/5	0.36/0.09 0.45/0.11 0.45/0.11	2.7/3.0 2.7/3.0 2.7/3.0	- - -	1 1 1	27 27 27	10 10 10

Table 0-6 GCHHTD technical data

ISO (FEM) classification	M3 (1Bm) 150 s/h 25% duty	M4 (1Am) 180 s/h 30% duty	M5 (2m) 240 s/h 40% duty	M6 (3m) 300 s/h 50% duty	M7 (4m) 360 s/h 60% duty	Lifting speed	Motor power (M6/M4)	3 x 400V 50Hz (M6/M4)	1 x 230V 50Hz (M6/M4)	No. of chain falls	Dead weight 2 m lift	Connection fuse
Types	Capacity [kg]					[m/min]	[kW]	[A]	[A]		[kg]	[A]
GCHHTD 500/NF GCHHTD 500/SF	- -	- 250	- 200	250 160	200 125	8/2 12.5/3	0.36/0.09 0.57/0.14	2.7/3.0 2.7/3.0	- -	1 1	35 35	10 10

Table 0-7 GCHR technical data

ISO (FEM) classification	M3 (1Bm) 150 s/h 25% duty	M4 (1Am) 180 s/h 30% duty	M5 (2m) 240 s/h 40% duty	M6 (3m) 300 s/h 50% duty	M7 (4m) 360 s/h 60% duty	Lifting speed	Motor power (M4)	3 x 400V 50Hz (M4)	1 x 230V 50Hz (M4)	No. of chain falls	Dead weight 3 m lift	Connection fuse
Types	Capacity [kg]					[m/min]	[kW]	[A]	[A]		[kg]	[A]
GCHR 500/1N GCHR 500/1NF	- -	320 320	250 250	- -	- -	8 8/2	0.46 0.46/0.12	2.1 2.9/3.0	- -	1 1	20 22.5	10 10
GCHR 500/2N GCHR 500/2NF	- -	630 630	500 500	- -	- -	4 4/1	0.46 0.46/0.12	2.1 2.9/3.0	- -	2 2	24.5 25	10 10
GCHR 1000/1N GCHR 1000/1NF	- -	630 630	500 500	- -	- -	8 8/2	0.91 0.91/0.23	3.7 4.0/2.8	- -	1 1	45 46	10 10
GCHR 1000/2N GCHR 1000/2NF	- -	1'250 1'250	1'000 1'000	- -	- -	4 4/1	0.91 0.91/0.23	3.7 4.0/2.8	- -	2 2	50 51	10 10

EC DECLARATION OF CONFORMITY

Declaration for machinery according to EU directives 2006/42/EC, Annex II A, 2004/108/EC, Annex I and 2006/95/EC, Annex III

We,

GIS AG, Hebe- und Fördertechnik, Luzernerstrasse 50, CH-6247 Schötz



hereby declare that the following machinery

**GIS electric chain hoist, series
payload range**

**GCH
100 kg - 5000 kg**

developed for lifting and lowering loads, is, in standard production and from the 2005 model year, inclusive of load control, meets the essential requirements of the following EC directives, as applicable to the scope of the delivery:

EC Machinery Directive	2006/42/EC
EC Directive on Electromagnetic Compatibility	2004/108/EC
EC Low Voltage Directive	2006/95/EC

Harmonized standards applied:

ISO 2374	Lifting appliances; Range of maximum capacities for basic models
DIN EN 818-7	Short link chain for lifting purposes; Part 7: Grade T
DIN EN ISO 13849-1	Safety-related parts of control systems; Part 1: General principles for design
DIN EN 14492-2	Cranes, power driven winches and hoists; Part 2: Power driven hoists
DIN EN 60204-32	Electrical equipment of machines; Part 32: Requirements for hoisting machines

Standards and technical specifications applied:

FEM 9.751	Power driven series hoist mechanisms; Safety
FEM 9.755	Measure for achieving safe working periods

Authorized to compile relevant technical documentation:

Mr. Pius Engel, GIS AG, Luzernerstrasse 50, CH-6247 Schötz.

Schötz, 11.10.2010

GIS AG

I. Muri
Director

E. Leiva
Sales Manager

Responsible for completion, installation and commissioning as per instructions:

Place: Date:

Responsible:

Company:

EC DECLARATION OF INCORPORATION

Declaration for the incorporation of partly completed machinery according to EU directives 2006/42/EC, Annex II B, 2004/108/EC, Annex I and 2006/95/EC, Annex III

We,

GIS AG, Hebe- und Fördertechnik, Luzernerstrasse 50, CH-6247 Schötz

hereby declare that the following partly completed machinery



**GIS electric chain hoist, series
payload range**

**GCH
100 kg - 5000 kg**

developed for lifting and lowering loads, is, in standard production and from the 2005 model year, inclusive of load control, intended for installation in machinery and meets the essential requirements of the following EC directives, as applicable to the scope of the delivery:

EC Machinery Directive	2006/42/EC
EC Directive on Electromagnetic Compatibility	2004/108/EC
EC Low Voltage Directive	2006/95/EC

We also declare that the technical documentation has been compiled in accordance with Annex VII, Part B of Directive 2006/42/EC. We undertake to submit the specific documents relating to the lifting mechanism to national authorities on receipt of a reasonable request. The information will be supplied by electronic means.

Harmonized standards applied:

ISO 2374	Lifting appliances; Range of maximum capacities for basic models
DIN EN 818-7	Short link chain for lifting purposes; Part 7: Grade T
DIN EN ISO 13849-1	Safety-related parts of control systems; Part 1: General principles for design
DIN EN 14492-2	Cranes, power driven winches and hoists; Part 2: Power driven hoists
DIN EN 60204-32	Electrical equipment of machines; Part 32: Requirements for hoisting machines

Standards and technical specifications applied:

FEM 9.751	Power driven series hoist mechanisms; Safety
FEM 9.755	Measure for achieving safe working periods

This declaration only refers to the lifting mechanism. Commissioning is prohibited until it has been firmly ascertained that the crane, in which the lifting mechanism is installed, complies with the provisions of the above EC directives.

Authorized to compile relevant technical documentation:

Mr. Pius Engel, GIS AG, Luzernerstrasse 50, CH-6247 Schötz.

Schötz, 11.10.2010

GIS AG

T. Muri
Director

E. Leiva
Sales Manager

Responsible for completion, installation and commissioning as per instructions:

Place: Date:

Responsible:

Company: